

# SATRON VDt Differential Pressure Transmitter

**SATRON VDt differential pressure transmitter** belongs to V-transmitter family. The series V transmitters have both analog and smart properties. SATRON VDt is used for 0-0,1kPa...0-15 MPa ranges. It is a 2-wire transmitter with HART® standard communication. In pressure measuring applications SATRON VDt transmitters are used for measuring differential pressure and absolute pressure. SATRON VDt transmitter is equipped with an SOS (Silicon On Sapphire) or piezoresistive sensing element. The rangeability is 25:1.

## TECHNICAL SPECIFICATIONS

### Measuring range and span

See Selection Chart.

### Zero and Span adjustment

Zero elevation: Calibrated span is freely selectable on the specified range depending from the desired option. This can be made by using external control shafts (analog option), keyboard (display option), HART®275/375 communicator.

### Damping

Time constant is continuously adjustable 0,01 to 60 s.

### Temperature limits

Sensing element operating:

- 30 to +125 °C

Electronics operating: -30 to +80 °C

Shipping and storage: -50 to +80 °C.

Operating temperature of display: 0 to +50°C (does not affect operation of the transmitter)

### Pressure limits

Min. and max. process pressure:

Type	Max. overload pressure, MPa	Pressure class
VDt2	4	PN40
VDt3	10	PN100
VDt4,5	10	PN100
VDt6	10	PN100
VDt3,4,5,7	40	PN420
VDt6	15	PN420

Transmitter operates within specifications for pressures above 10 mbar abs.

### Process chamber volume (cm<sup>3</sup>)

Type	Volume (cm <sup>3</sup> )	
	Standard transmitter	with hydraulic seal
VDt2...7	2.5	2.0

**Volume of negative-side process chamber:** < 1 cm<sup>3</sup>.

**Output 2-wire (2W), 4-20 mA,** user selectable for linear, square root, inverted signal or the transfer function (16 points) specified by the user

### Supply voltage and permissible load

See the load capacity diagram;  
4-20 mA output: 12 - 35 VDC.

### Humidity limits

0-100 % RH

### PERFORMANCE SPECIFICATIONS

Tested in accordance with IEC 60770: Reference conditions, specified span, no range elevation, horizontal mounting; AISI316L-diaphragm, silicone oil fill.

#### Accuracy

±0.05 % of calibrated span  
(span 1:1-5:1 / max.range).

On the measuring ranges 5:1-60:1:

$\pm[0.01+0.008 \times (\frac{\text{max. span}}{\text{calibrated span}})]\%$  of calibrated span

#### Special accurate diaphragm AISI304:

±1.5 % of calibrated span  
(For spans 1:1 - 60:1)

(incl. nonlinearity, hysteresis and repeatability)

#### Long-term stability

±0.1 % of max. span / year

#### Temperature effect on compensated temperature ranges -20 to 80 °C

Zero and span shift: ±0,15 % of max. span

#### Static pressure effect on Zero of max. span

VDt2: ±0,2 % / 4 MPa  
VDt3...5, PN100: ±0,2 % / 10 MPa  
VDt6...7, PN100 / PN400: ±0.3 % / 10 MPa

#### Overpressure effect on Zero of max. span

VDt2: ±0,5 % / 4 MPa;  
VDt3...7: PN100: ±0,3 % / 10 MPa;  
PN400: ±1 % / 40 MPa.

#### Mounting position effect

Zero error ± 0.4 kPa, which can be calibrated out.

#### Vibration effect (IEC 61298-3):

±0.1 % of measuring range

#### Power supply effect

< ±0.01 % of calibrated span / volt.

#### Insulation test voltage

500 V rms 50 Hz

## CONSTRUCTION AND CALIBRATION

### Materials

Diaphragms <sup>1)</sup>: AISI316L (EN 1.4435), AISI304 (EN 1.4301), Duplex (EN 1.4462), Hast. C276 (EN 2.4819) or Tantalum.

Flanges <sup>1)</sup> and vent valves <sup>1)</sup>: AISI316, Duplex or Hast. C276.



O-ring on sensing element: PTFE. Other sensing element materials: AISI316, SIS 2343, SIS 2324. Mounting bolts and nuts for sensor flanges: AISI316 (PN400: m.8.8.Zne)

### Fill fluid

Silicone oil (DC200, 10 cSt) or inert oil.

### Housing with PLUG connector, H and T

Housing: AISI316

Seals: Viton® and NBR

TEST jacks: MS358Sn/PVDF, protected with silicone rubber shield.

PLUG connector: PA6-GF30 jacket, Silicone rubber seal, AISI316 retaining screw.

### Housing with junction box/terminal strip, M and N

Housing: AISI303/316; Seals: Nitrile and Viton®; Nameplates: Polyester

### Connection cable between sensing element and housing

Codes L and K :

PTFE hose with AISI316 braiding.

**Enclosure class:** IP66.

### Process connections

See Selection Table.

### Calibration

For customer-specified range with 1 s. damping. Min. factory calibration range: 10mbar (VDt2). (If range is not specified, transmitter is calibrated for maximum range.)

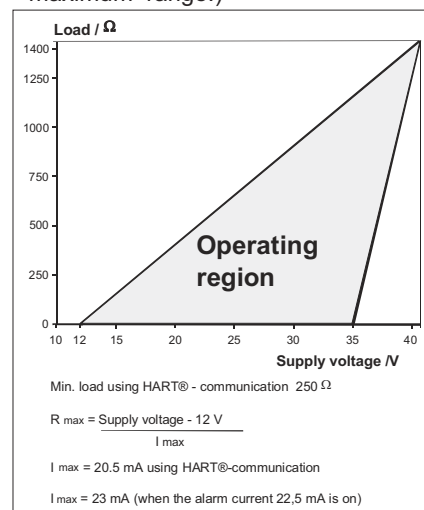

<sup>1)</sup> Parts in contact with process medium.

### Electrical connections

Housing with PLUG connector, **H** and **T**:  
PLUG connector, connector type DIN 43650 model AF; Pg9 gland for cable; wire cross-section 0.5 to 1.5 mm<sup>2</sup>.

Housing with junction box/terminal strip, **M** and **N** :  
M20x1.5, 1/2-NPT inlet; screw terminals for 0.5 to 2.5 mm<sup>2</sup> wires

### Product Certifications

#### European Directive Information

#### Electro Magnetic Compatibility (EMC directive 2004/108/EC)

All differential pressure transmitters

#### European Pressure Equipment Directive (PED) (97/23/EC)

All Differential Pressure Transmitters :  
- Sound Engineering Practice

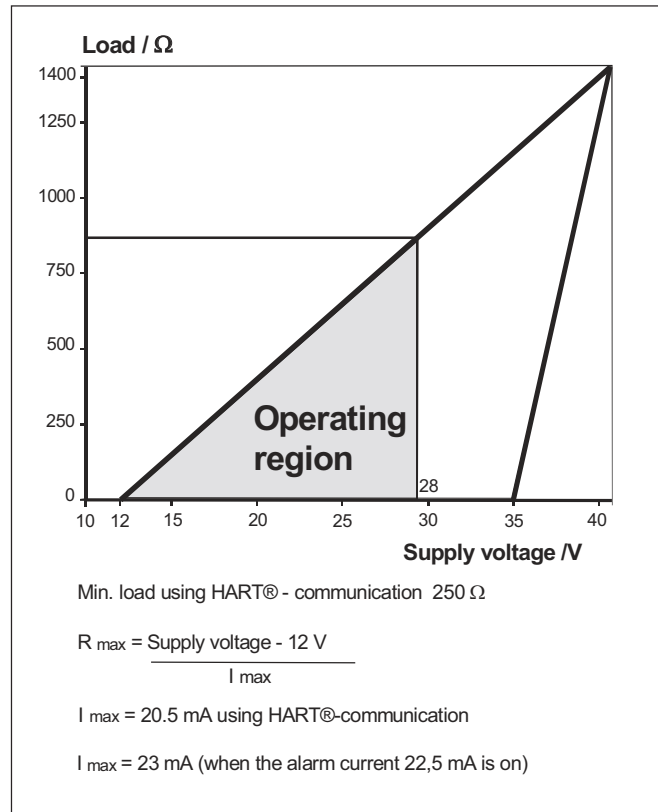

### Weight (kg)

Type	Housing type		
	H	M	N
VDt2 ... 7	4,0	4,6	4,6

Dimensions (in mm)

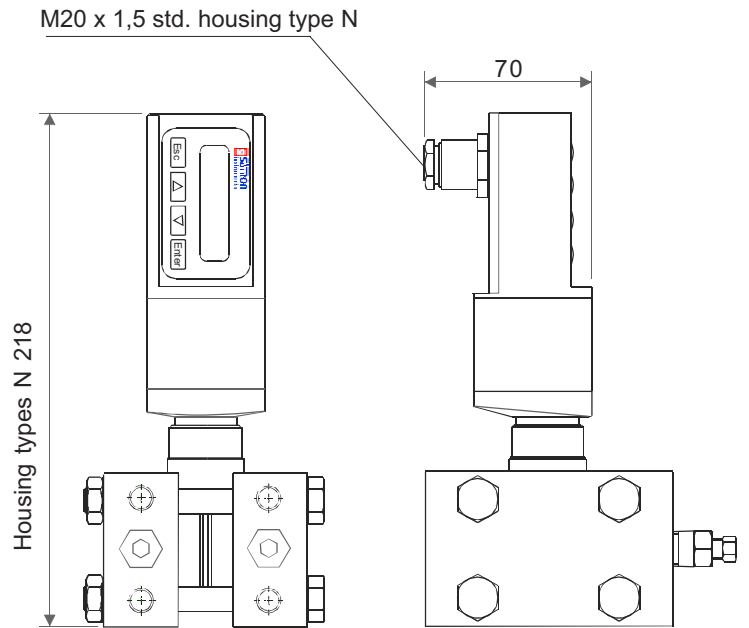
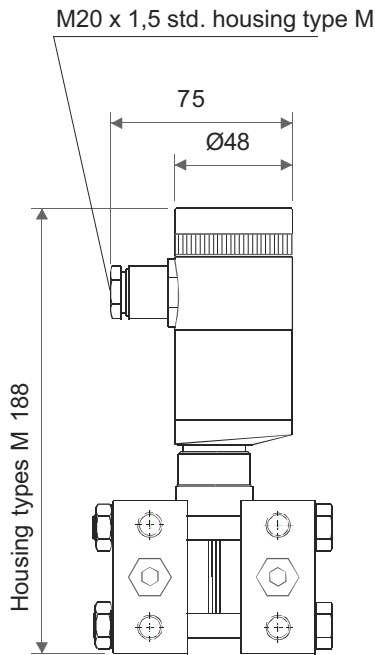
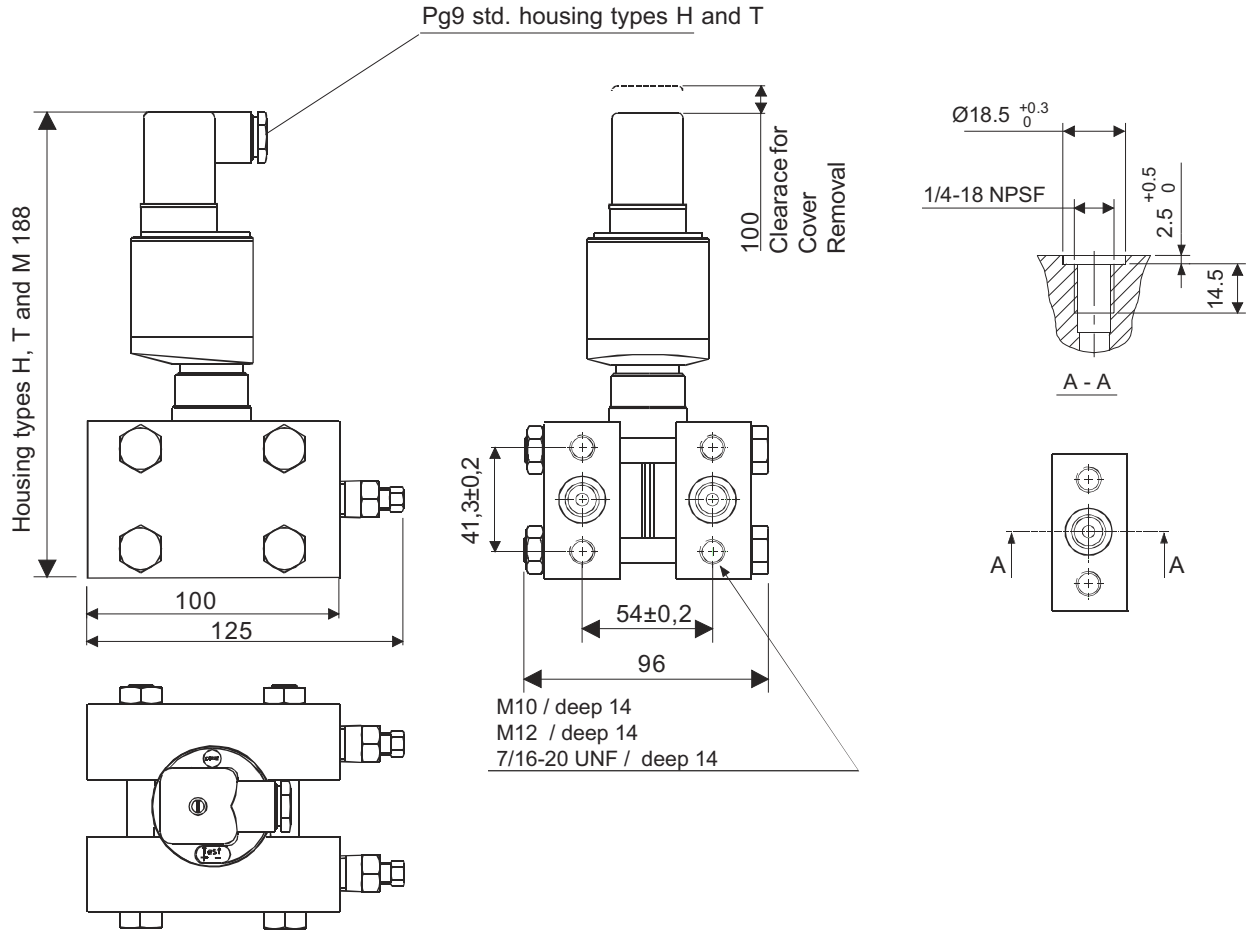

## Dimensions (in mm)

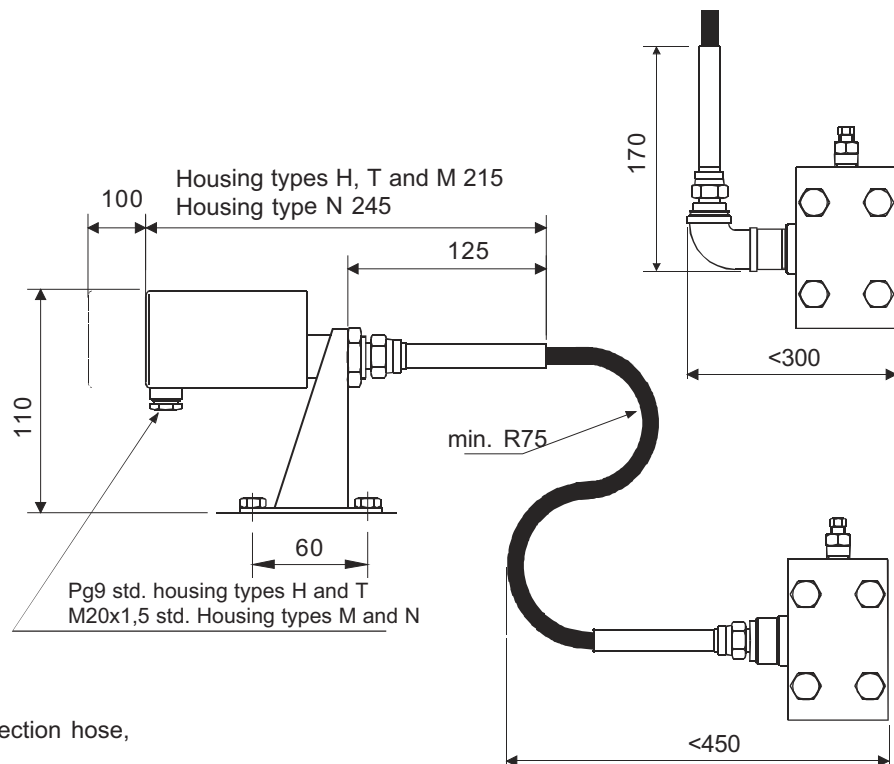
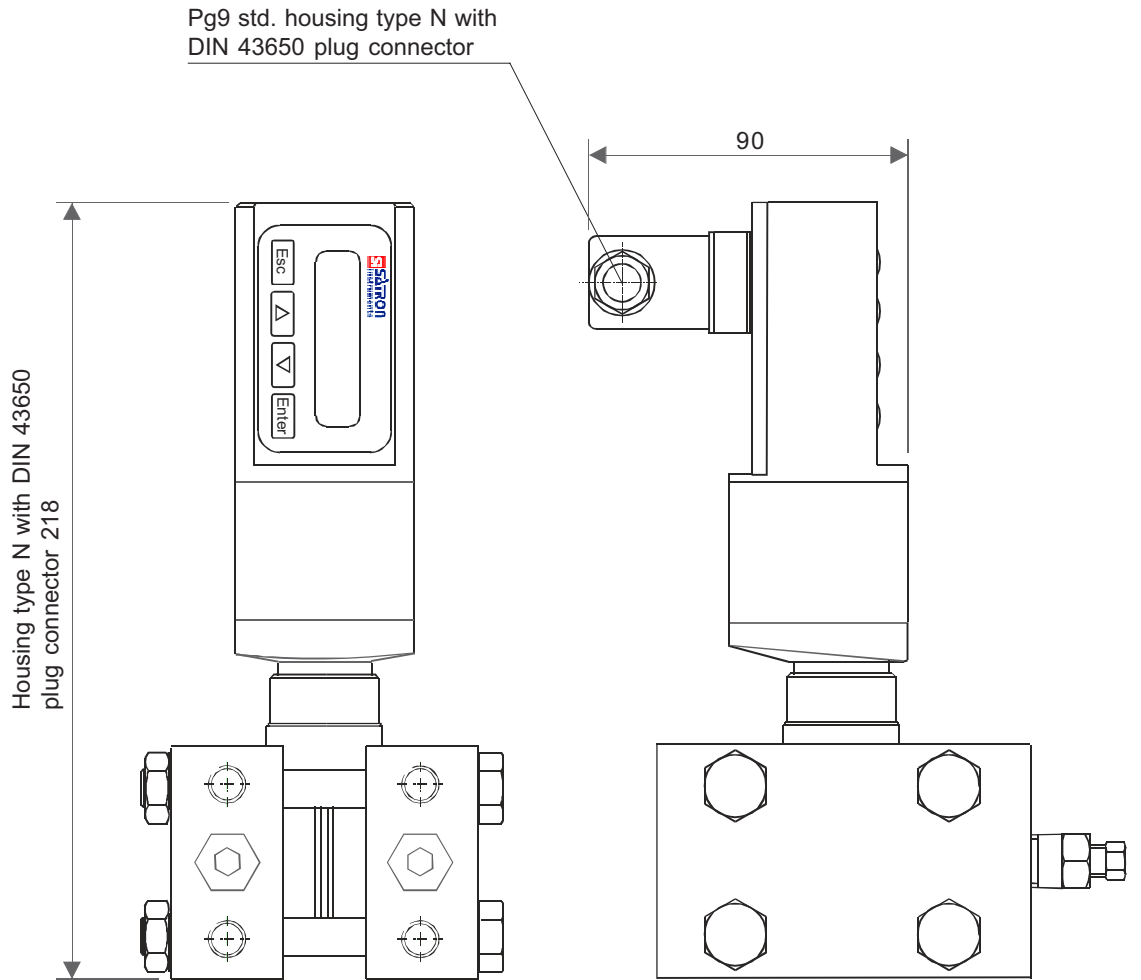

Remote electronics,  
connecting cable with protection hose,  
codes L and K

## Housing with PLUG connector, code T

Use of selector switch :

- RUN = working position
- PZ = Process value zero
- D = Damping adjustment
- S = Span adjustment
- Z = Zero adjustment
- DN = Down
- UP = Up

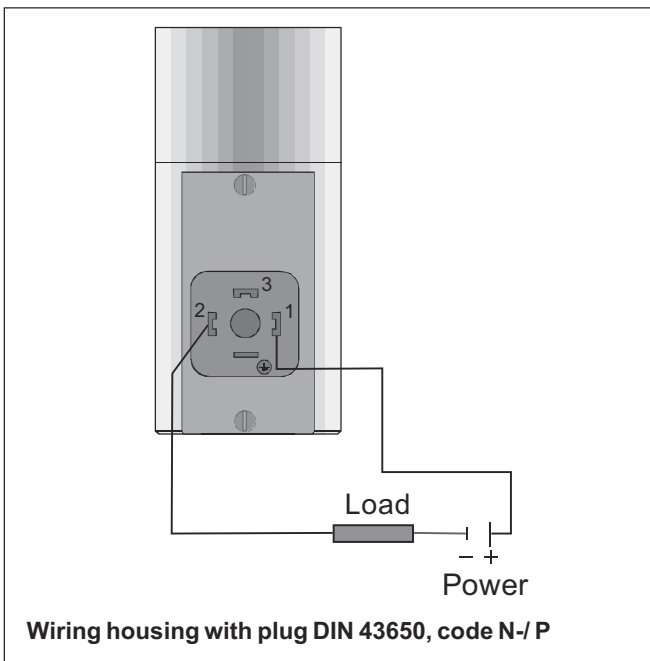
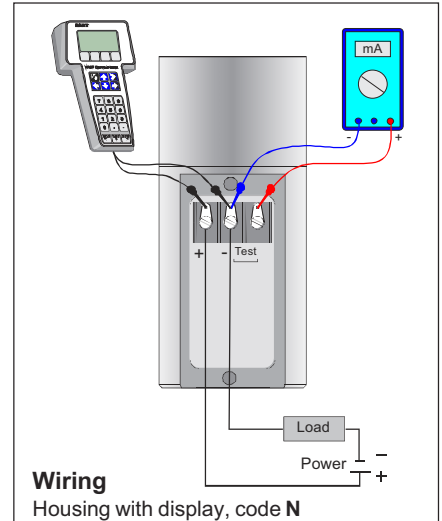
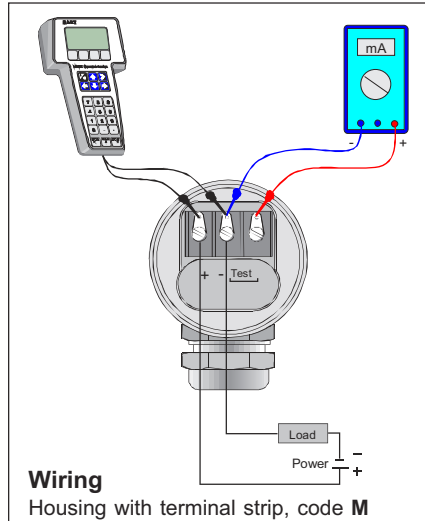
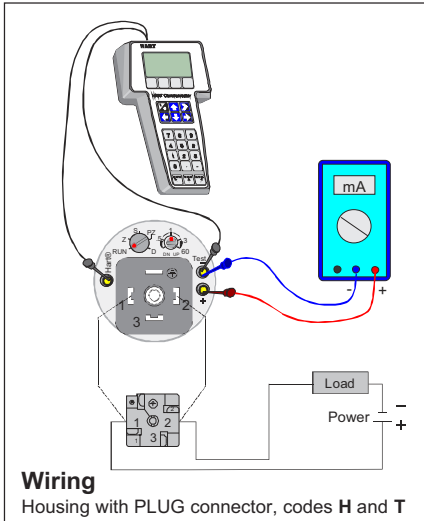
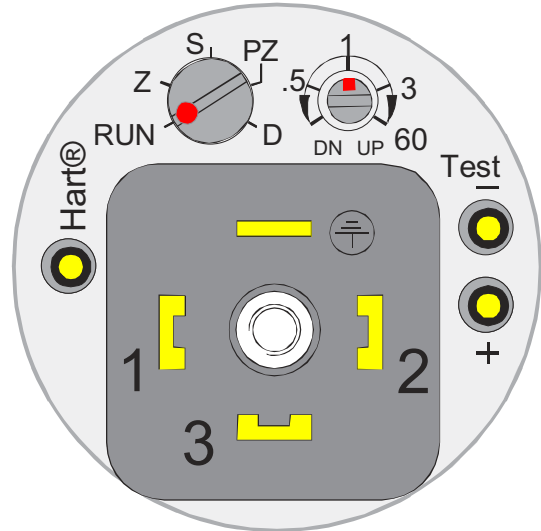

## Housing with display, code N

Keyboard :

- Esc = Press **Esc** move back towards the top of the main menu.
- ▲ = Use the **UP** arrow key to move up on the current menu level or to increase the selected parameter value.
- ▼ = Use the **DOWN** arrow key to move down on the current menu level or to decrease the selected parameter value.
- Enter = Press **ENTER** to move to a lower level in a menu or to accept a command or parameter value.

## Selection Chart

VDt	Differential Pressure Transmitter	VAt	Absolute Pressure Transmitter (ranges 4 to 7, range 0...xx, abs.)
<b>Adjustability ( ± )</b>			
	<b>Span, min.</b>	<b>Span, max.</b>	<b>Measurig range</b>
<b>2</b>	0,1 kPa (1 mbar) (*)	6 kPa (60 mbar)	-6...+6 kPa (-60...+60 mbar)
<b>3</b>	1,4 kPa (14 mbar)	35 kPa (350 mbar)	-35 kPa...+35 kPa (-350...+350 mbar)
<b>4</b>	4 kPa (40 mbar)	100 kPa (1000 mba)	-100...+100 kPa (-1000...+1000 mbar)
<b>5</b>	26,5 kPa (265 mbar)	500 kPa (5000 mbar)	-500...+500 kPa (-5000...+5000 mbar)
<b>6</b>	0,145 MPa (1,45 bar)	3 MPa (30 bar)	-3...+3 MPa (-30...+30 bar)
<b>7</b>	1 MPa (10 bar)	15 MPa (150 bar)	-15...+15 MPa (-150...+150 bar)
<b>Output</b>			
<b>S</b>	4-20mA DC/HART® -protocol		
<b>Process connection</b>			
<b>D</b>	M10,PN40 range 2/PN100 ranges 3...6, IEC 61518	<b>F</b>	Screwed flange adapters, PN40 range 2 and PN420 ranges 3 to 7, IEC 61518
<b>A</b>	M10, PN420 ranges 3, 4, 5 and 7, IEC 61518	<b>V</b>	Connection through hydraulic seal
<b>H</b>	M12, PN420 ranges 3, 4, 5 and 7, IEC 61518	<b>Z</b>	Welded flange adapters, PN420 ranges 3 to 5 and 7, IEC61518
<b>U</b>	7/16-20 UNF, (PN420 ranges 3, 4, 5 and 7)		
<b>Wetted material</b>			
	<b>Flanges</b>	<b>Diaphragm</b>	<b>Diaphragm coating</b>
	Code Material	Code Material	Code Material
	<b>2</b> AISI316L (EN 1.4404)	<b>2</b> AISI316L (EN 1.4435)	(specify only when coated)
	<b>3</b> Hast.C 276 (EN 2.4819)	<b>3</b> Hast.C 276 (EN 2.4819)(**)	<b>9</b> gold / rhodium
		<b>5</b> Tantalum (**)	
		<b>8</b> Duplex (EN 1.4462) (**)	
		<b>A</b> AISI304 (EN 1.4301) (**)	
<b>Fill fluid</b>			
	<b>S</b> Silicone oil	<b>G</b> Inert oil	
<b>Housing type</b>			
<b>H</b>	Housing with PLUG-connector, DIN43650, no display, inlet PG9		
<b>T</b>	Housing with PLUG-connector, DIN43650, no display, inlet PG9, with manual adjust		
<b>M</b>	Housing with junction box/terminal strip, no display, inlet M20x1,5		
<b>N</b>	Housing with junction box/terminal strip, with display, inlet M20x1,5		
<b>Explosion proof</b> <b>0</b> No explosion proof classification			
<b>Process thread on flange adapter</b> (only specify for type F)			
	<b>Thread type</b>	<b>Thread size</b>	
	Code Type	Code	Size
	<b>R</b> straight R thread	<b>2</b>	1/4
	<b>N</b> NPS thread	<b>3</b>	3/8
	<b>P</b> taper R thread	<b>4</b>	1/2
	<b>T</b> NPT thread		
<b>Special size of electrical inlet</b>			
<b>N</b>	1/2NPT	<b>G</b>	Pg13.5
		<b>P</b>	Plug DIN 43650
<b>Special features</b>			
<b>Special electronics</b> (specify only if housing connected with hose to sensing element)			
<b>- connecting cable with protection hose</b>			
<b>L</b>	Hose protected with PTFE/AISI316 braiding, straight		
<b>K</b>	Hose protected with PTFE/AISI316 braiding, angle of 90°		
<b>Length of cable between sensing element and housing</b>			
(specify only if housing connected with cable to sensing element)			
<b>2</b>	2 m cable	<b>3</b>	3 m cable etc. (max. 20 m)
<b>Mounting parts for remote electronics for Ø51 mm tube</b>			
<b>0</b>	No mounting parts		
<b>1</b>	Mounting parts		
<b>Documentation</b>			
<b>Calibration Certificate</b>		<b>AE</b> English	
<b>Installation and Operating Instructions</b>		<b>IE</b> English	<b>IF</b> Finnish
<b>Material Certificates</b>			
<b>0</b>	No material certificate		
<b>MC1</b>	Raw materials certificate without appendixes, in accordance with SFS-EN 10204-2.1 (DIN 50049-2.1) standard		
<b>MC2</b>	Raw materials certificate for wetted parts with appendixes, in accordance with SFS-EN 10204-2.2 (DIN 50049-2.2) standard		
<b>MC3</b>	Raw materials certificate for wetted parts with appendixes, in accordance with SFS-EN 10204-3.1B (DIN 50049-3.1B) standard		

We reserve the right for technical modifications without prior notice.  
 HART® is a registered trademark of HART Communication Foundation.  
 Viton® is the registered trademark of DuPont Down Elastomers.  
 Hastelloy® is the registered trademark of Haynes International.  
 Teflon® is the registered trademark of E.I. du Pont de Nemours & Co

(\*) = Minimum span for factory calibration 1kPa (10mbar)

(\*\*) = Not for ranges 2-3

